

RFID Read and Write Module

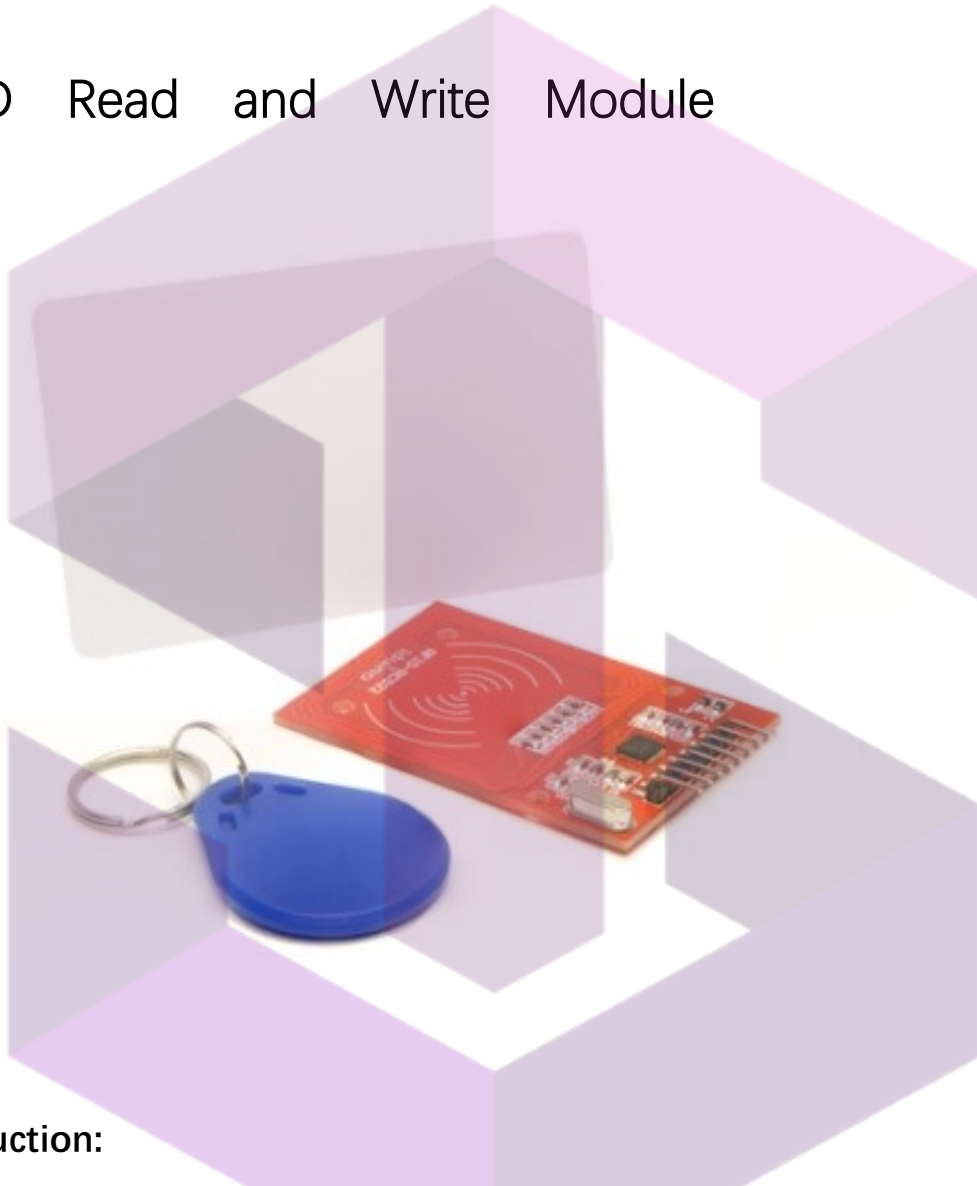

Instruction:

MF RC522 is applied to the highly integrated read and write 13.56MHz contactless communication card chip, NXP launched by the company for the "table" application of a low-voltage, low-cost, small size of non-contact card chip, smart meters and portable handheld devices developed better choice. The MF RC522 use of advanced modulation and demodulation concept completely integrated in all types of 13.56MHz passive contactless communication methods and protocols. In addition, support rapid CRYPTO1 encryption algorithm, terminology validation MIFARE products. MFRC522 support MIFARE series of high-speed non-contact communication, two-way data transmission rate up to 424kbit/s. As new members of the 13.56MHz reader card series of highly integrated chip family, MF RC522 MF RC500 MF RC530 There are a lot of similarities, but also have many of the characteristics and differences. Communication between it and the host SPI mode helps to reduce the connection narrow PCB board volume, reduce costs.

تهیه و توزیع قطعات الکترونیک

Electrical Parameters

Operating current: 13—26mA/DC 3.3V

Idle current: 10-13mA/ DC 3.3V

Sleep current: <80uA

Peak current: <30mA

Operating frequency: 13.56MHz

Supported Cards: mifare1 S50, mifare1 S70, mifare UltraLight, mifare Pro, mifare Desfire

Physical features: size: 40mm×60mm

Ambient operating temperature: - 20-80 degrees centigrade

Ambient storage temperature: - 40-85 degrees centigrade

Ambient relative humidity: 5%—95%

Module Interface SPI Parameters

Data Transfer Rate: Max. 10Mbit / s

SKYTECH

تهیه و توزیع قطعات الکترونیک

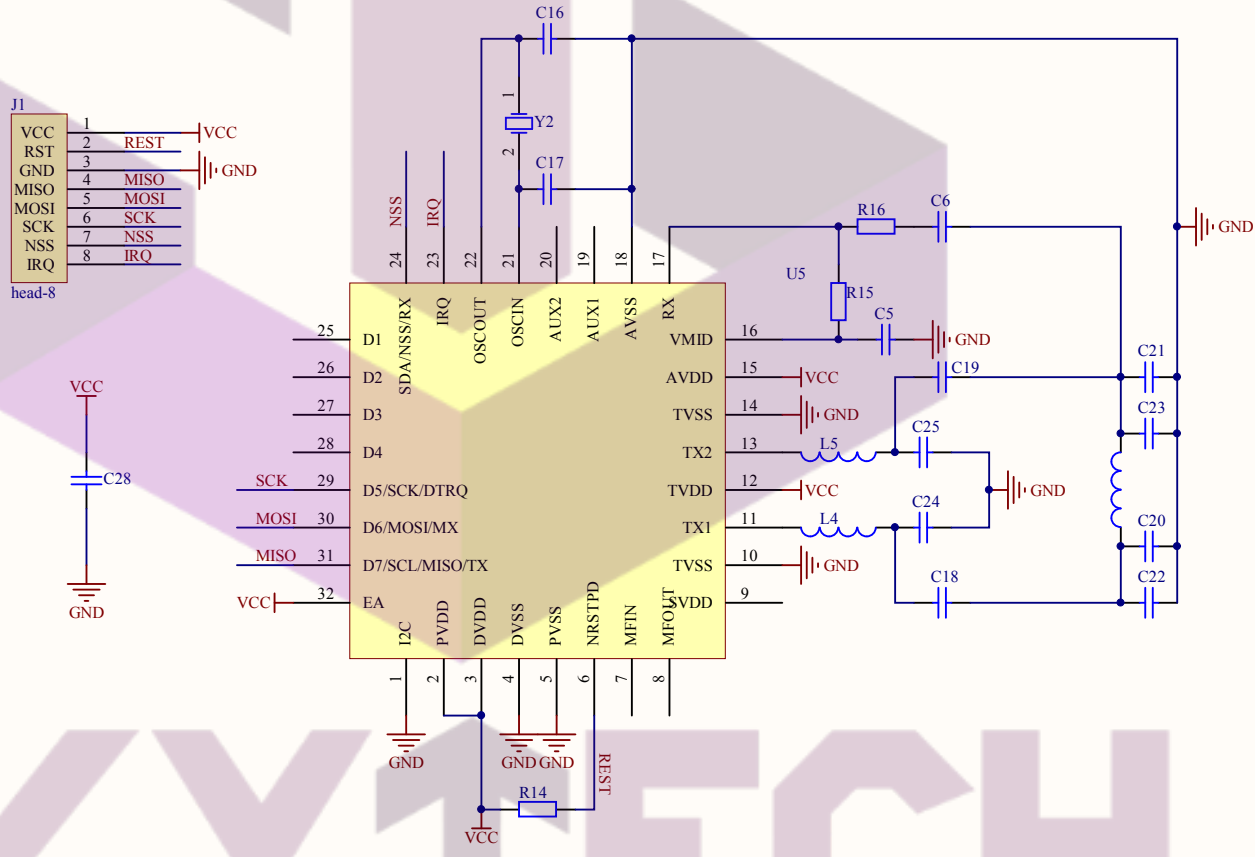

SKYTECH

تهيئه وتوزيع قطعات الكترونيك

Title		
Size	Number	Revision
A4		
Date:	2016-9-26	Sheet of
File:	C:\Documents and Settings\RFID.SchDoc Drawn By:	

RFID Entrance Guard System

Introduction

RFID is short for radio frequency identification. It is a wireless application to transfer data in the purpose of identifying and tracking tags. In this experiment, we will use an RFID module, a relay, and an I2C LCD1602 to assemble an entrance guard system.



Components

- 1 * SunFounder Uno board
- 1 * USB data cable
- 1 * RFID module
- 1 * RFID key tag
- 1 * Relay
- 1 * I2C LCD1602
- Several jumper wires
- 1 * 3-Pin anti-reverse cable
- 1 * 4-Pin anti-reverse cable
- 1 * Breadboard

Experimental Principle

First, you need to know the ID of the RFID key tag and write the ID to the rfidTest file. Compile the code. We can see "Welcome!" display on the I2C LCD1602. Swipe the RFID key ring on the RFID module. If the password is correct, the normally open contact of the relay will be closed and the LCD will display a string "ID:5AE4C955" "hello SunFounder", and then "Welcome!" two seconds later; if the password is incorrect, the normally open contact of the

relay will be disconnected and the LCD will display a string "Hello unknown guy" , and then "Welcome!" two seconds later

Note: For this module, please use a 3.3V power supply, or it will get burnt.

Experimental Procedures

Step 1: Connect the circuit

The wiring between RFID and SunFounder Uno is as follows:

RFID	SunFounder Uno
VCC	3.3V
RST	2
GND	GND
MISO	3
MOSI	4
SCK	5
NSS	6
IRQ	7

The wiring between I2C LCD1602 and SunFounder is as follows:

I2C LCD1602	SunFounder Uno
GND	GND
VCC	5v
SDA	A4
SCL	A5

The wiring between Relay Module and SunFounder is as follows:

Relay Module	SunFounder Uno
SIG	8
VCC	5V
GND	GND

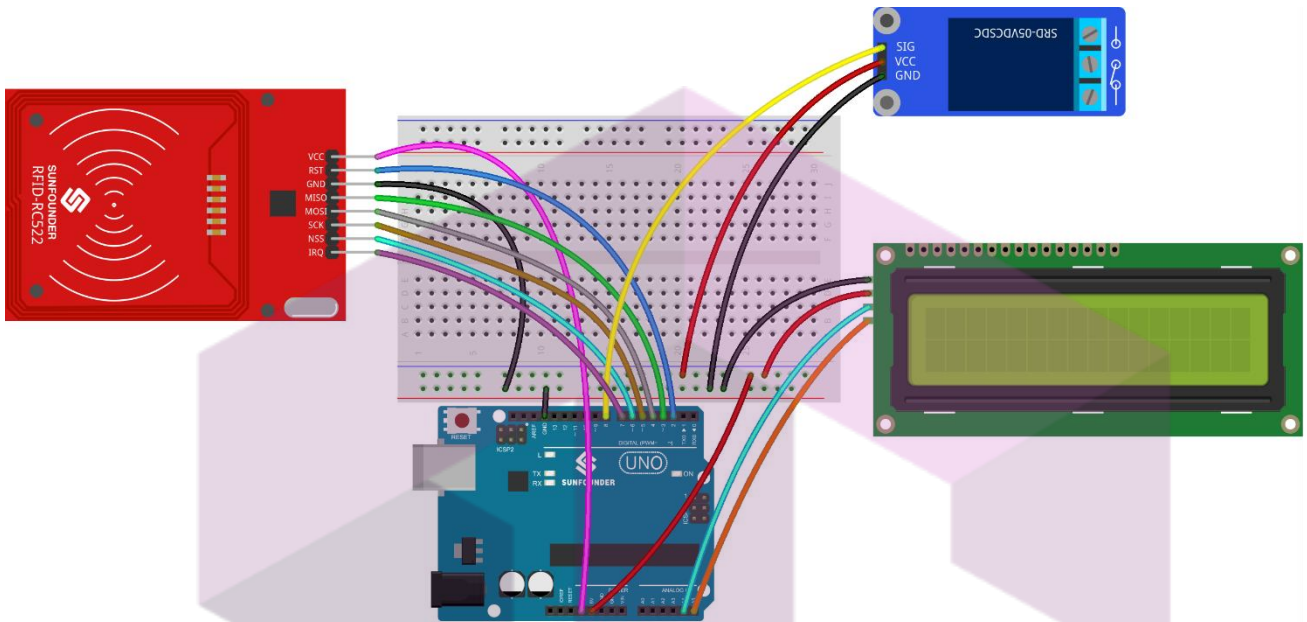

fritzing

Step 2: Open the **getId** file with Arduino IDE (Please refer to the example **code**). Before you compile the code, you need to add the three folders under the path `RFID-RC522 test experiment\code\library` to the Arduino IDE libraries folder, then compile the code.

Step 3: Upload the sketch to the SunFounder Uno board

Then place the RFID key tag in the induction zone of the RFID module. You will see the following values printed on Serial Monitor:

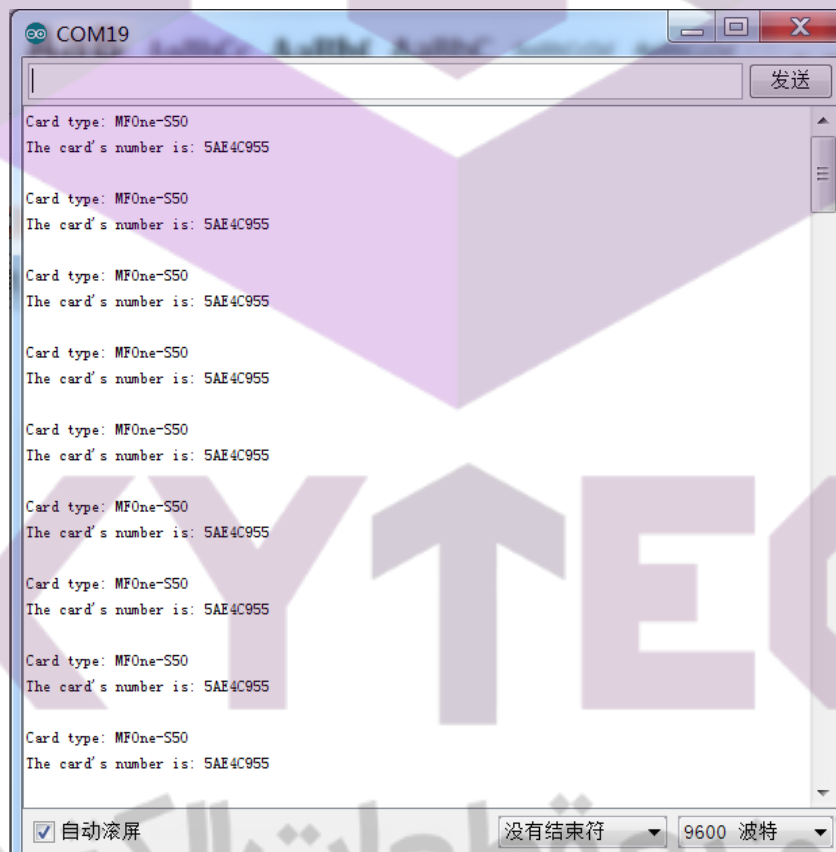

Step 4: Now, you may know the ID of your RFID key tag (e.g. my magnetic card ID is 5AE4C955).

Open the **rfidTest** file and replace the ID in the sketch with the ID you just note down (divide the ID into four parts and fill them according to the following format), as follows:

```
else if(id[0]==0x5A && id[1]==0xE4 && id[2]==0xC9 && id[3]==0x55)
{
    digitalWrite(relayPin, LOW);
    //Serial.println("Hello SunFounder");
    lcd.setCursor(0,1);
    lcd.print("Hello SunFounder");
    delay(2000);
    lcd.clear();
    digitalWrite(relayPin, HIGH);
}
```

Step 5: Burn the sketch into SunFounder Uno board

Now, swipe the RFID key tag on the RFID module. If the password is correct, the LCD will display a string "ID:5AE4C955" "Hello SunFounder", and then display "Welcome!" two seconds later. If the password is incorrect, the LCD will display a string "Hello unknown guy", and then display "Welcome!" two seconds later.

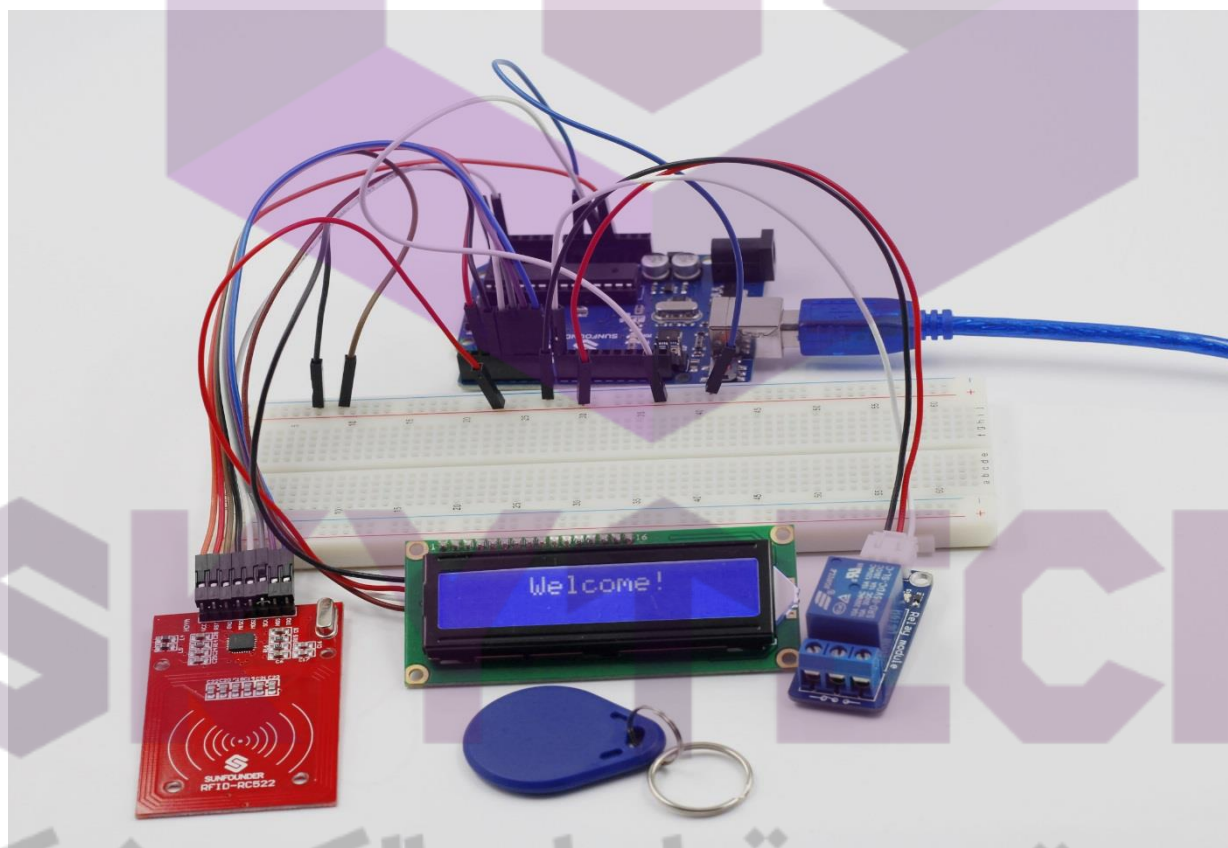

تهیه و توزیع قطعات الکترونیک

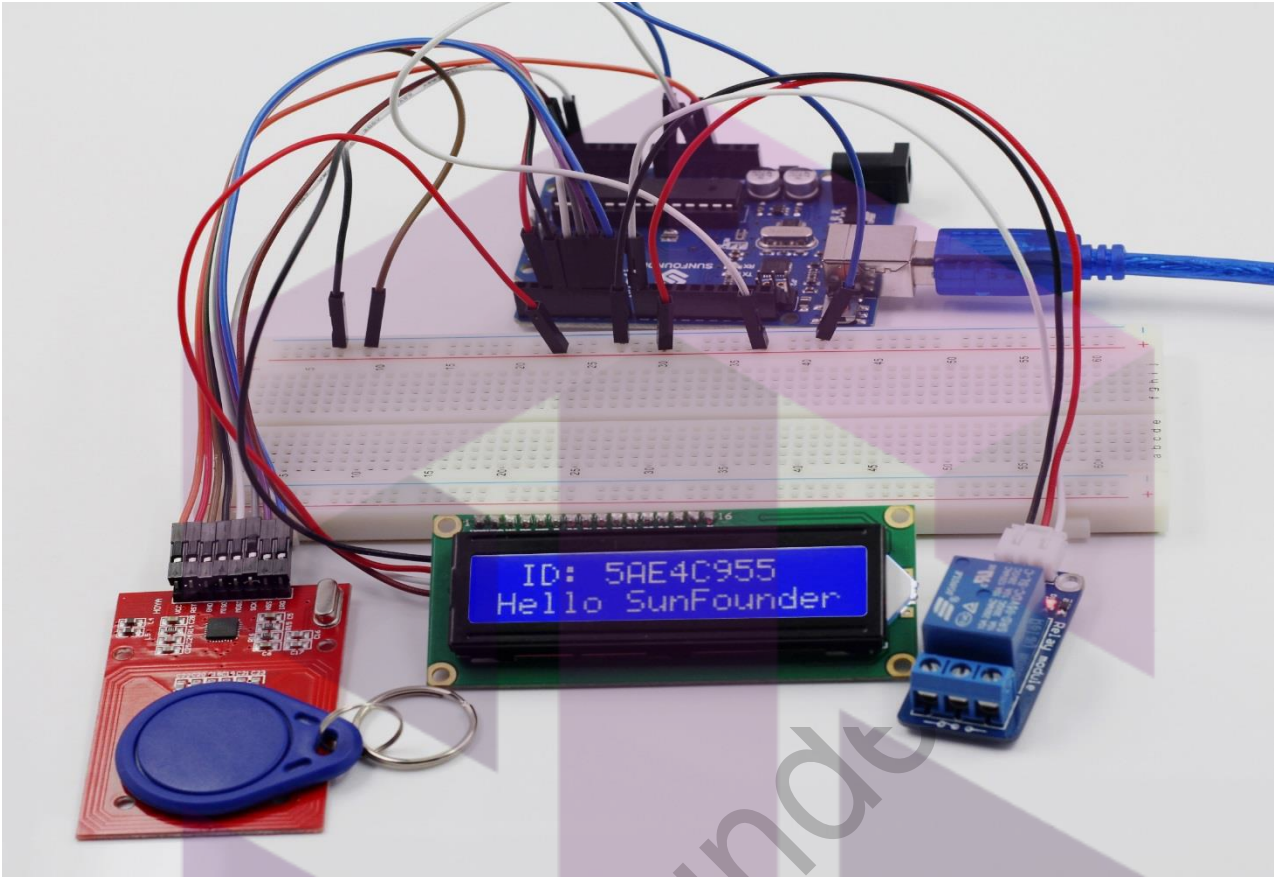

SKYTECH

تهیه و توزیع قطعات الکترونیک